

INTEX Comparator Beam Gauge

Developed to measure both internal and external diameters and lengths, the Intex gauge's aluminium extrusion beam gives it a rigid yet lightweight quality, making it ideal for shop-floor environments. The simple release of a locking thumbscrew enables the gauge's measuring direction to be changed quickly and easily.

WiFi
see p249 for wireless options

RS232

Features

- Lightweight and rigid
- Measuring ranges: 200-400mm, 400-600mm, 600-800mm, 800-1000mm
- Sizes over 1000mm available on request
- Internal and external measurement
- 2mm travel on moving contacts
- Adjustable fixed contacts with up to 250mm adjustment range
- Digital or analogue indicator available
- Hardened steel wear pads locate gauge onto component aiding repeatability and prolonging service life
- Setting master required to set the instrument



INTEX shown with standard contacts fitted (available as extras)

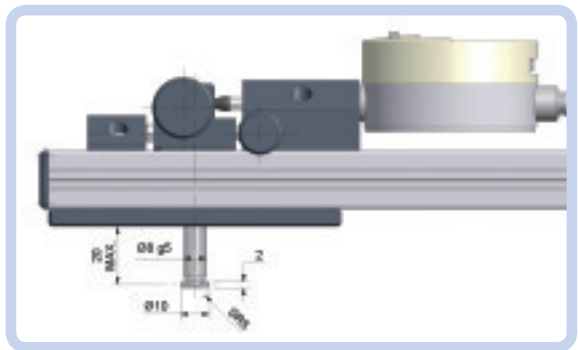

INTEXA01 - standard contacts

INTEX BEAM GAUGE - Without Indicator

Code No	Measuring Range
INTEX01	200-400mm
INTEX02	400-600mm
INTEX03	600-800mm
INTEX04	800-1000mm

Code No	Description
INTEXA01	Standard contacts - 10mm diameter (pair).

INTEX BEAM GAUGE - With Indicator

Code No	Measuring Range
INTEX01IND	200-400mm
INTEX02IND	400-600mm
INTEX03IND	600-800mm
INTEX04IND	800-1000mm